

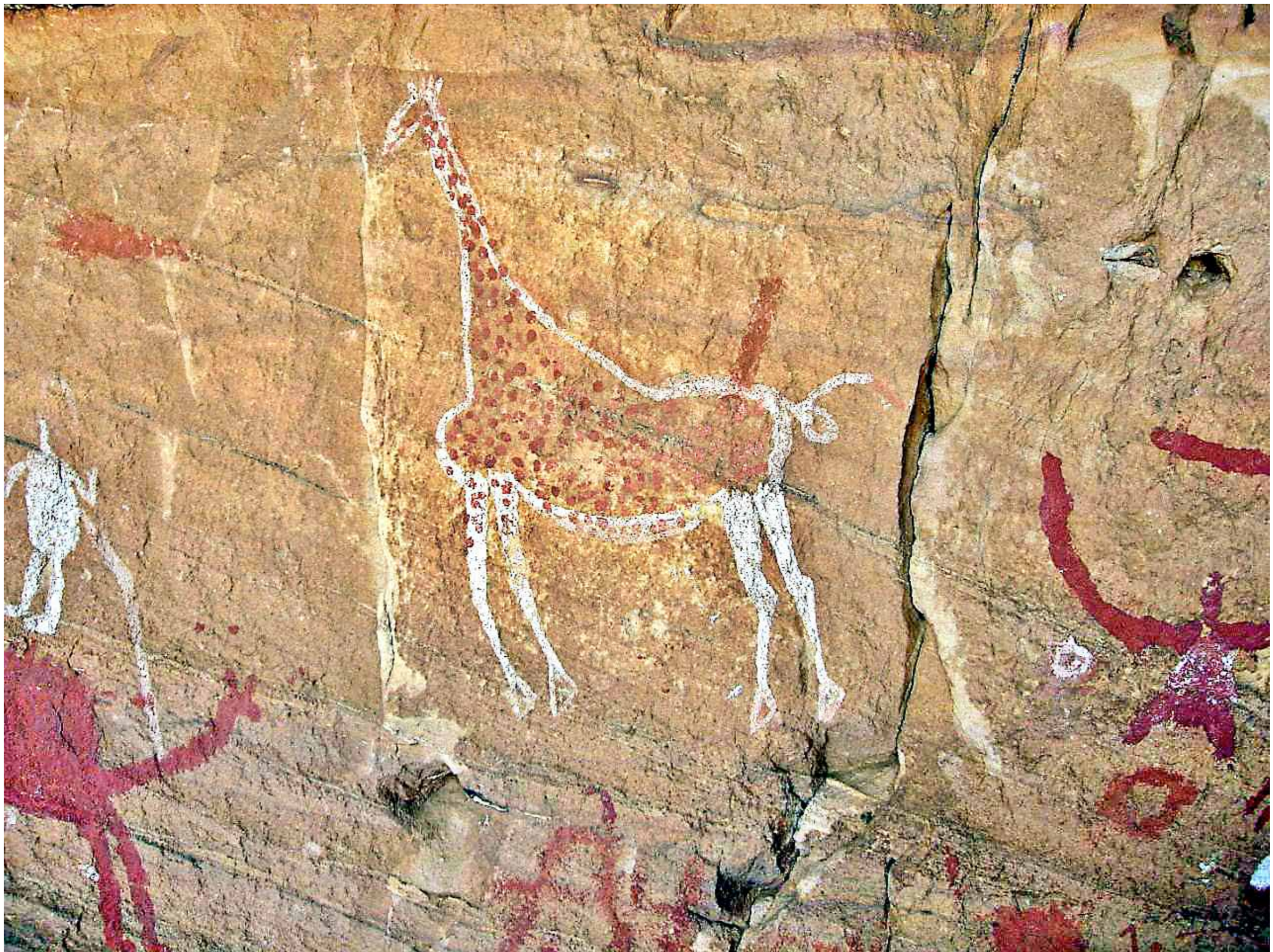

FOTOGRAFIA

*la storia di come l'uomo rappresenta la realtà
a modo suo*





CAMERA OSCURA

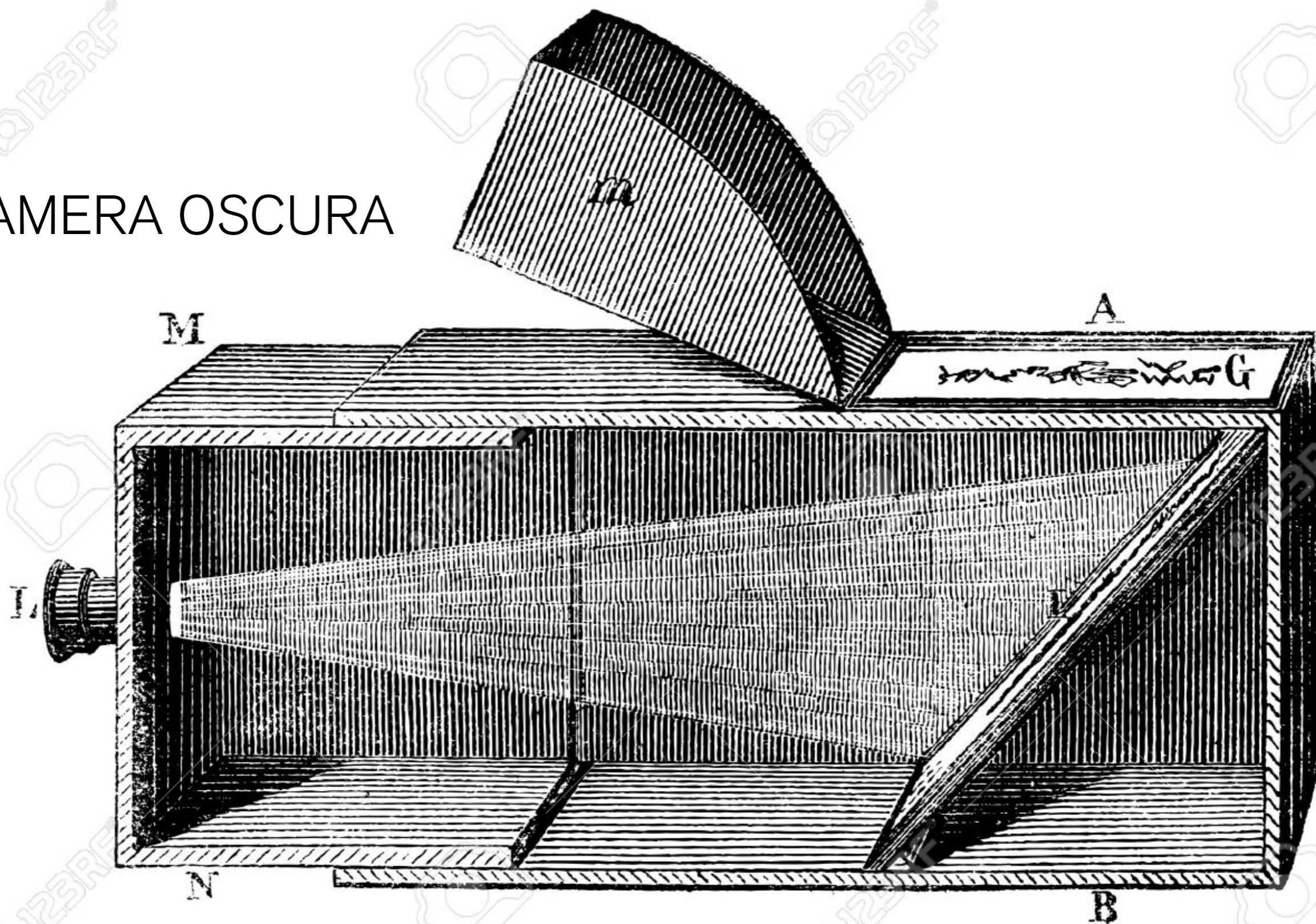

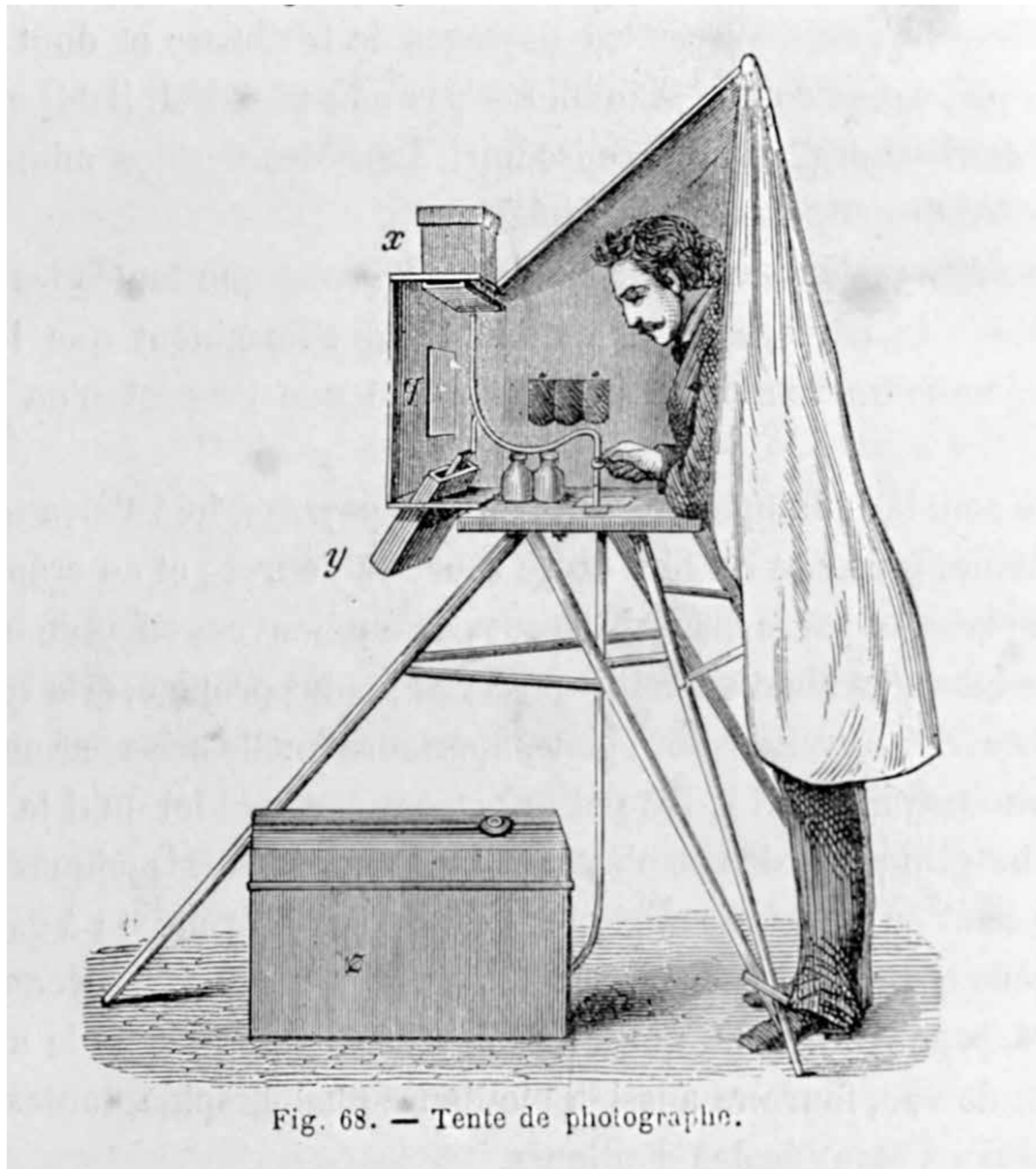
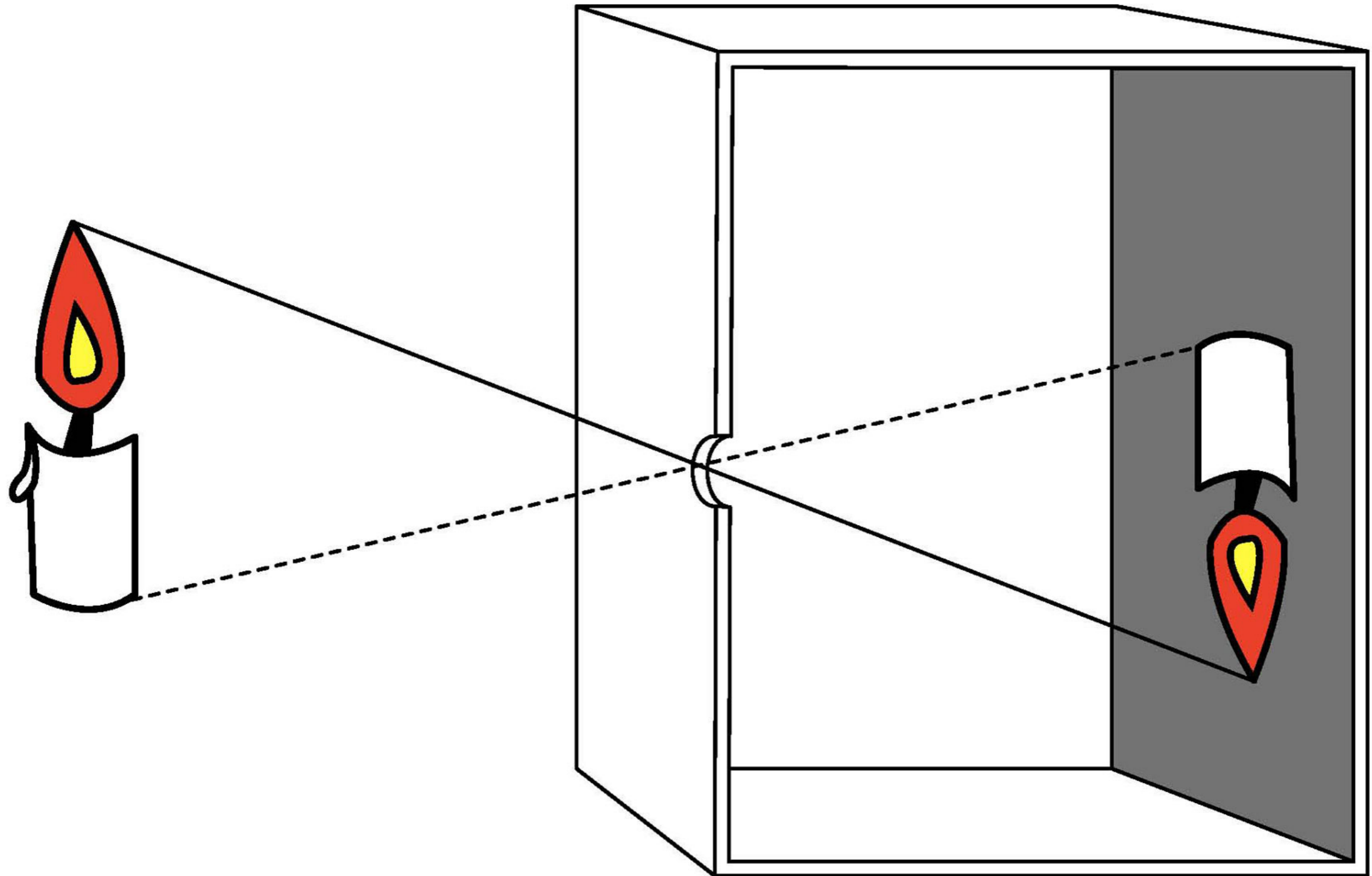

Fig. 68. — Tente de photographe.















DAGHERROTIPO

JOSEPH NIÉPCE 1826
eliografia

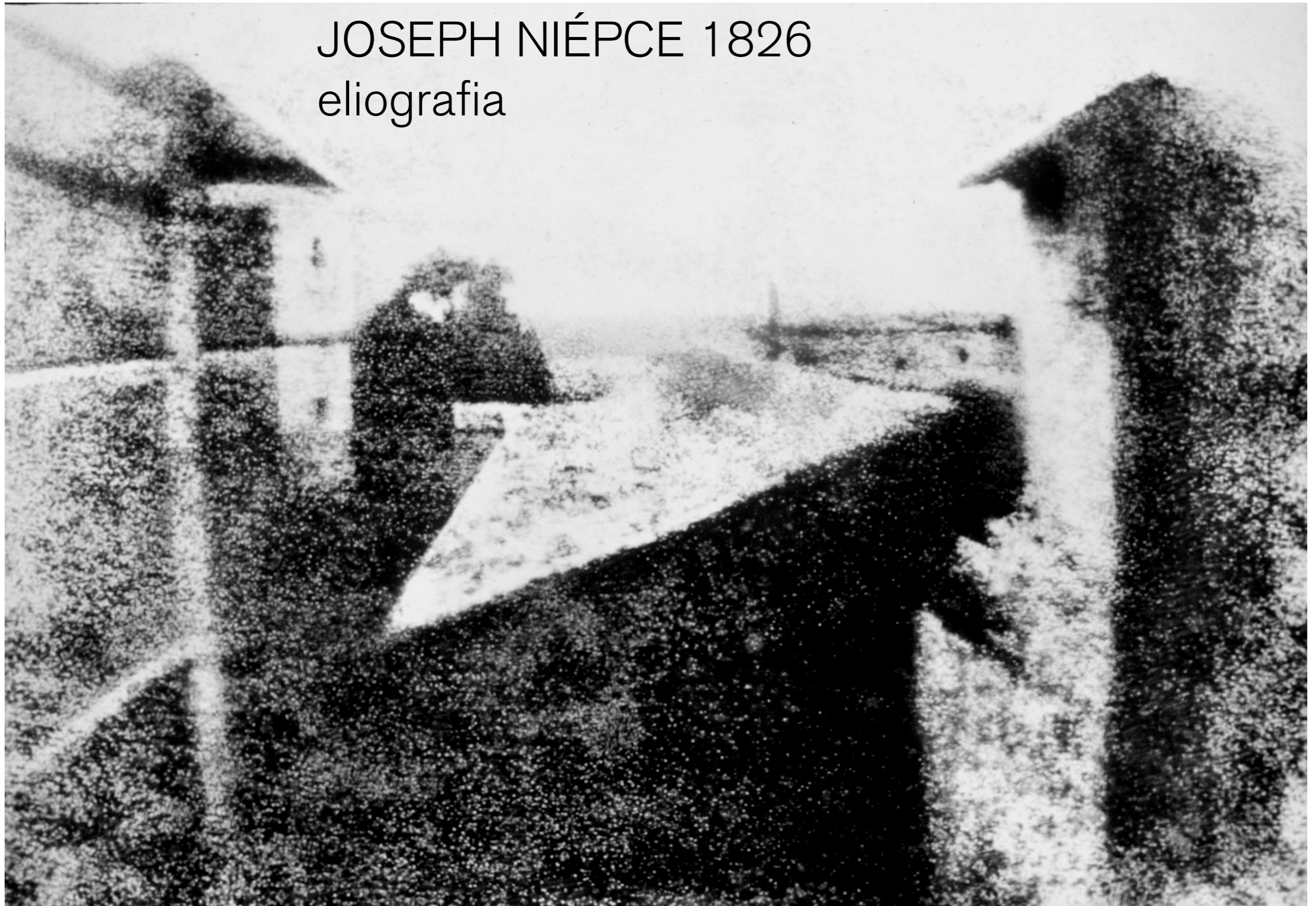









CALIOTIPIA

STUDIO NADAR - PARIGI

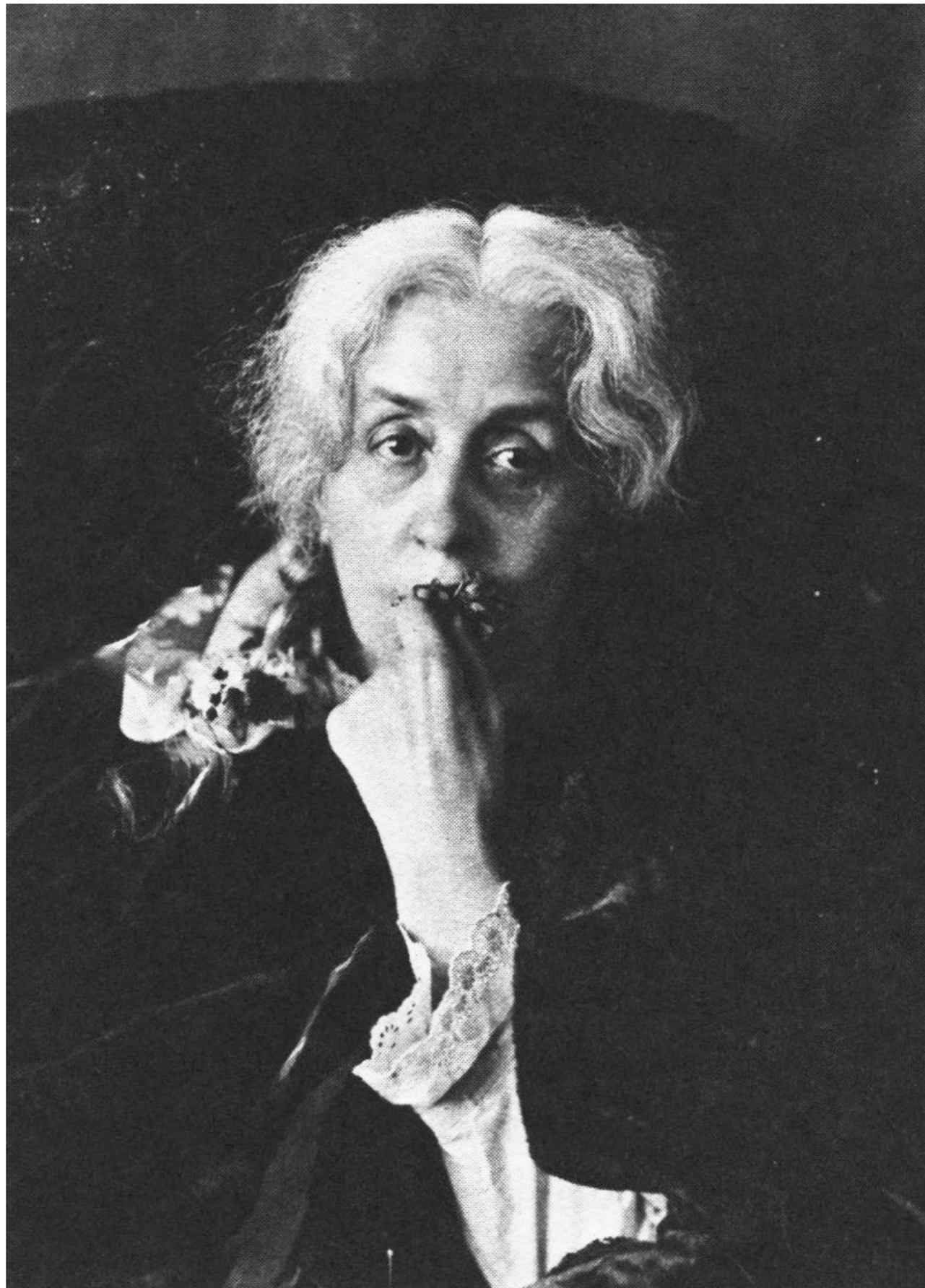

STUDIO NADAR - PARIGI



STUDIO NADAR - PARIGI

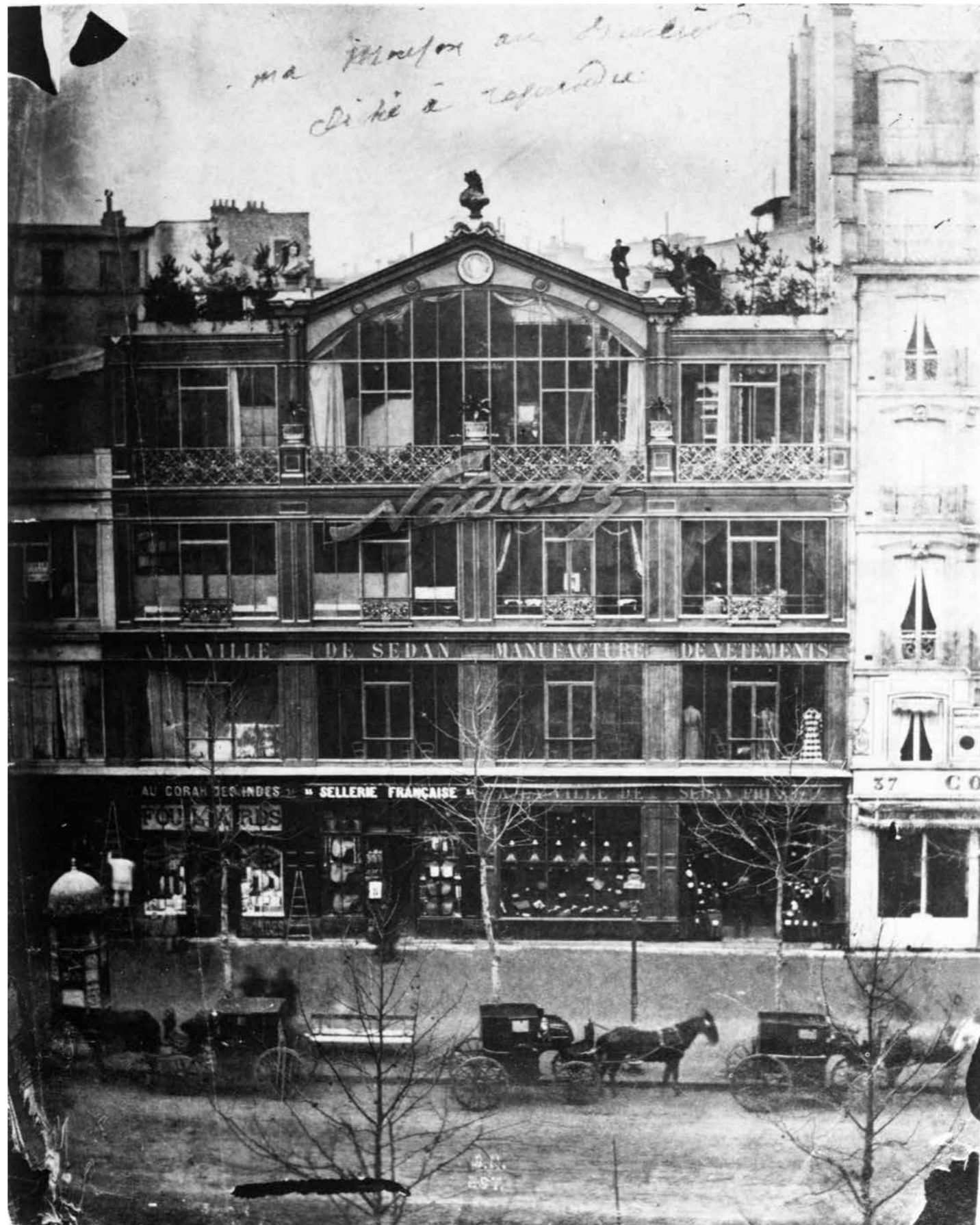

STUDIO NADAR - PARIGI



MAXWELL - prima fotografia colori (sovrapposizione filtri)

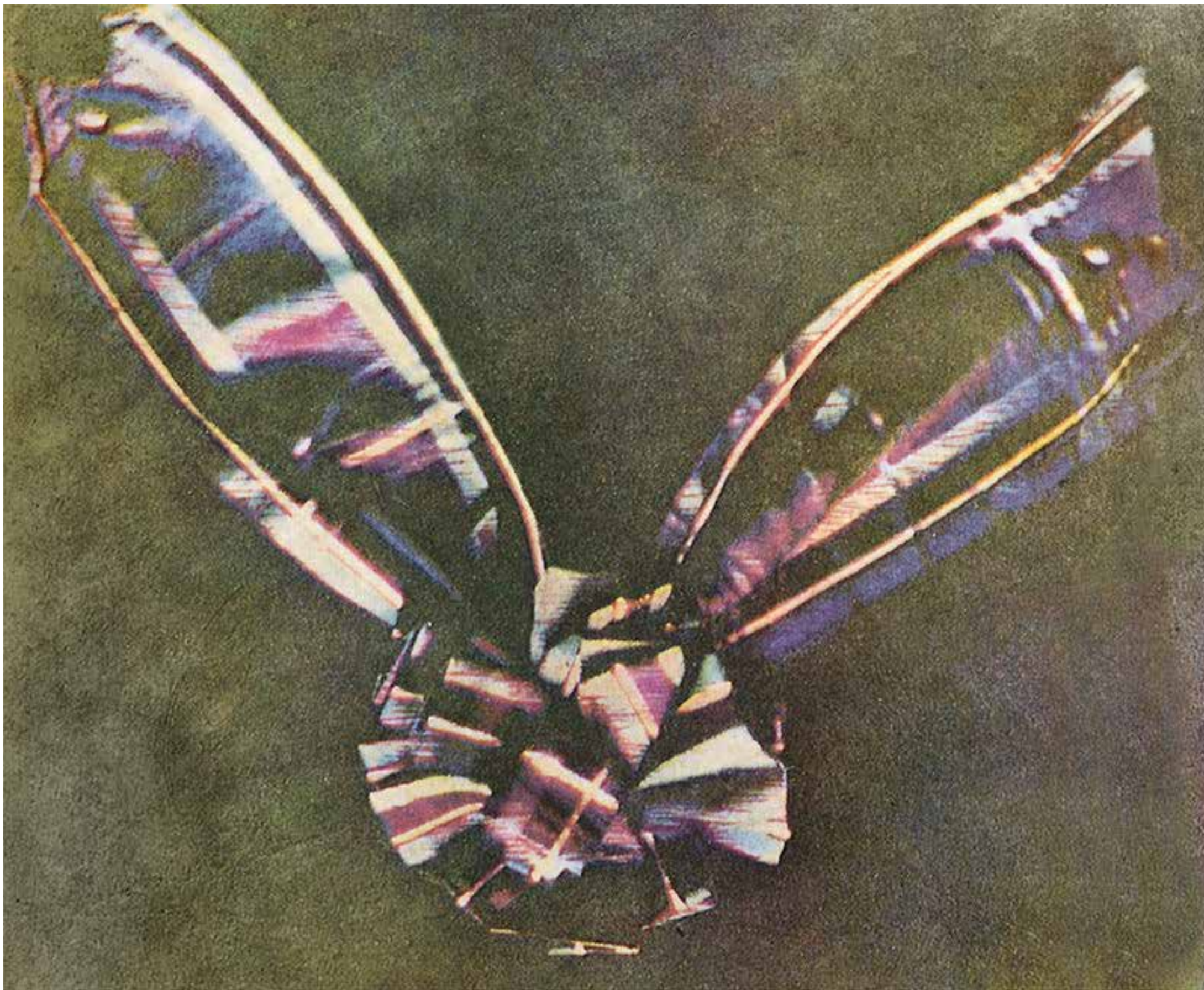

MANN RAY



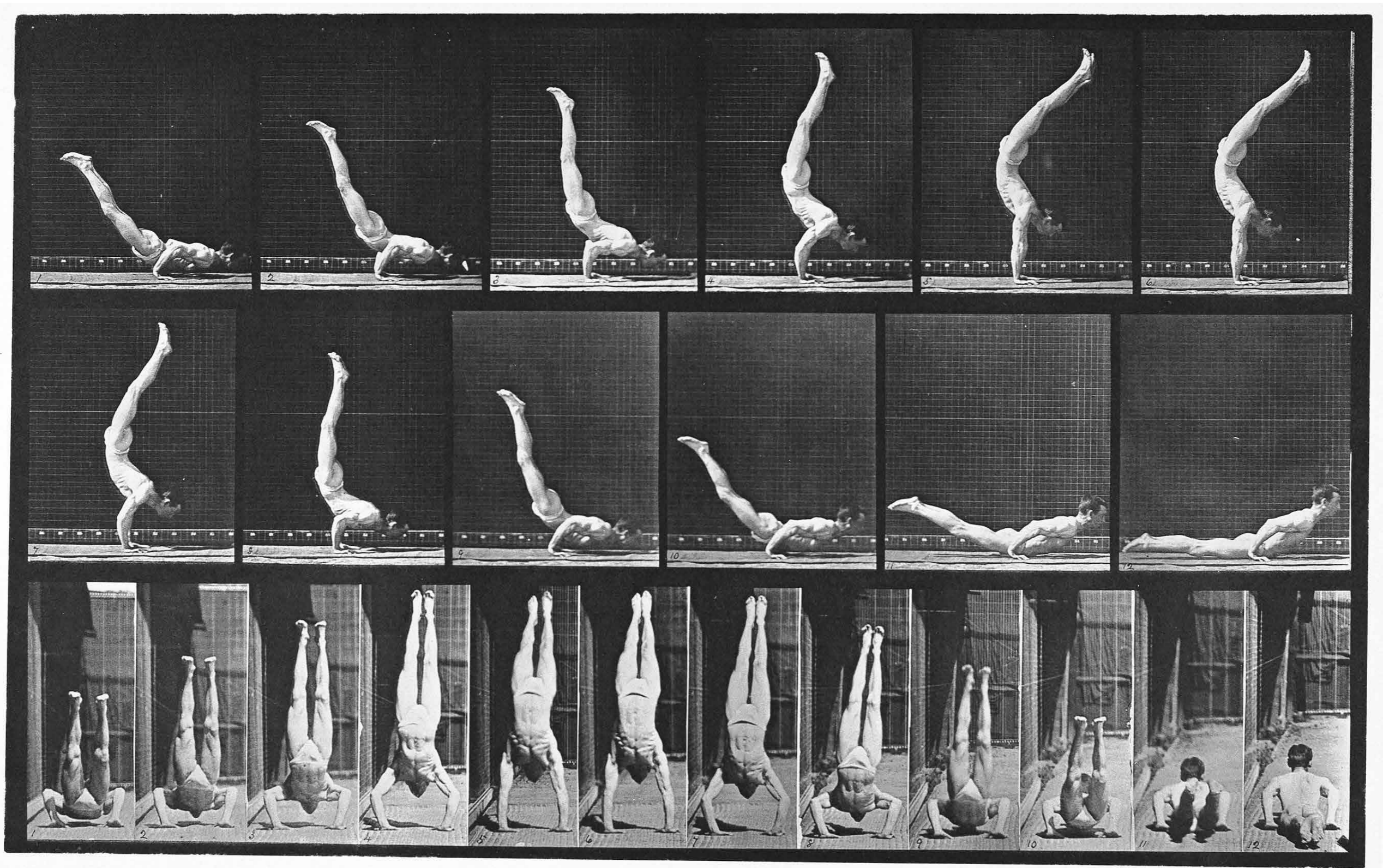

EADWEARD MUYBRIDGE

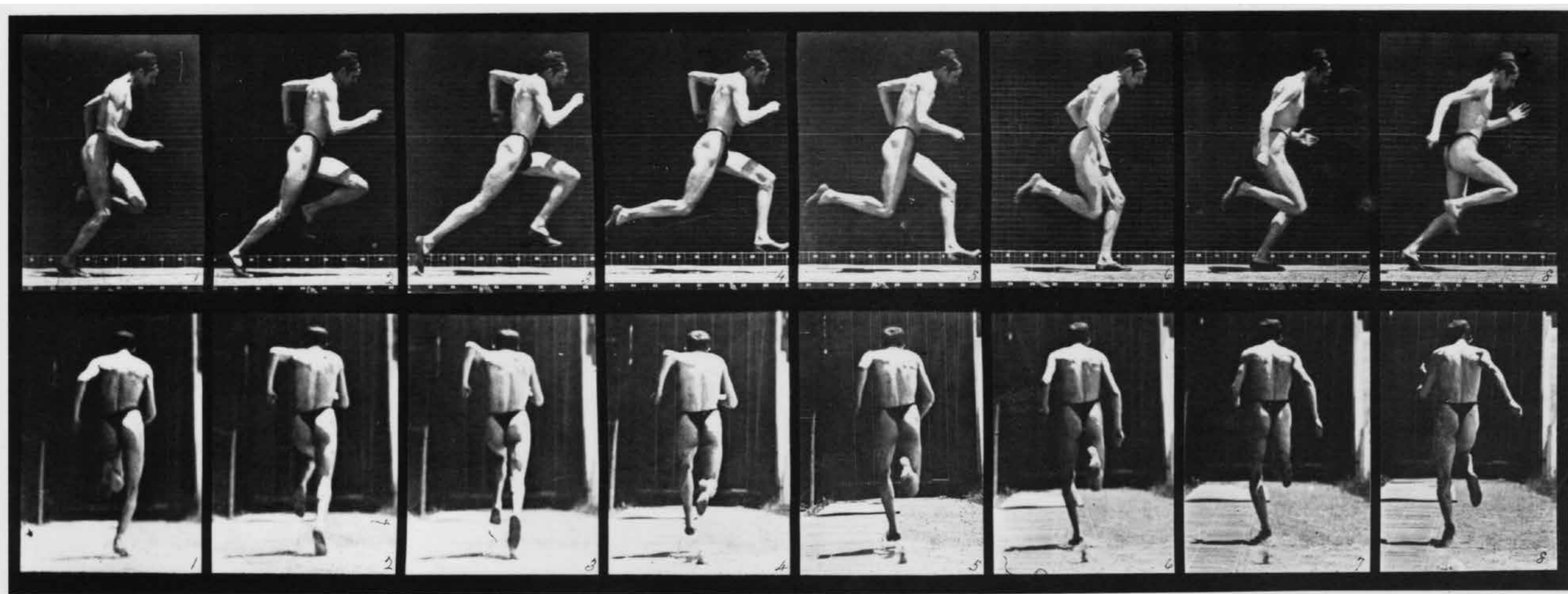

EADWEARD MUYBRIDGE

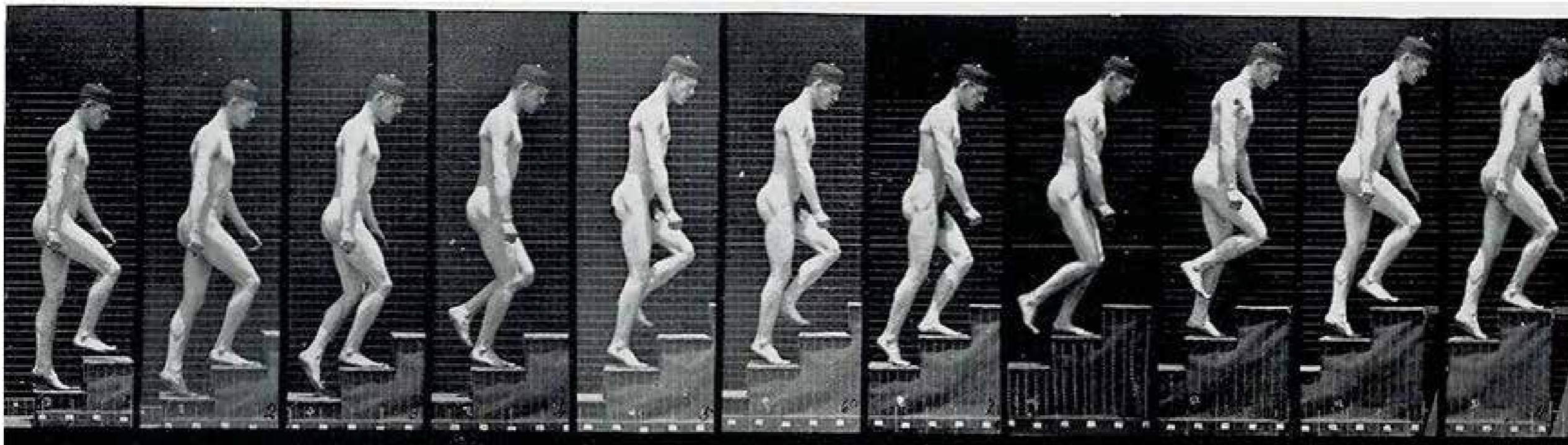
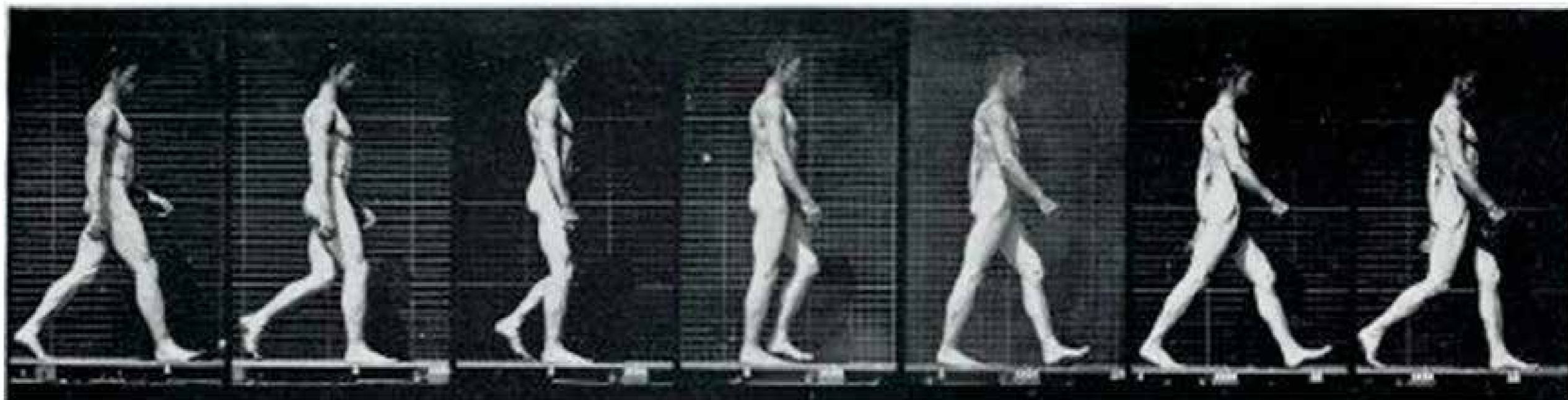

EADWEARD MUYBRIDGE

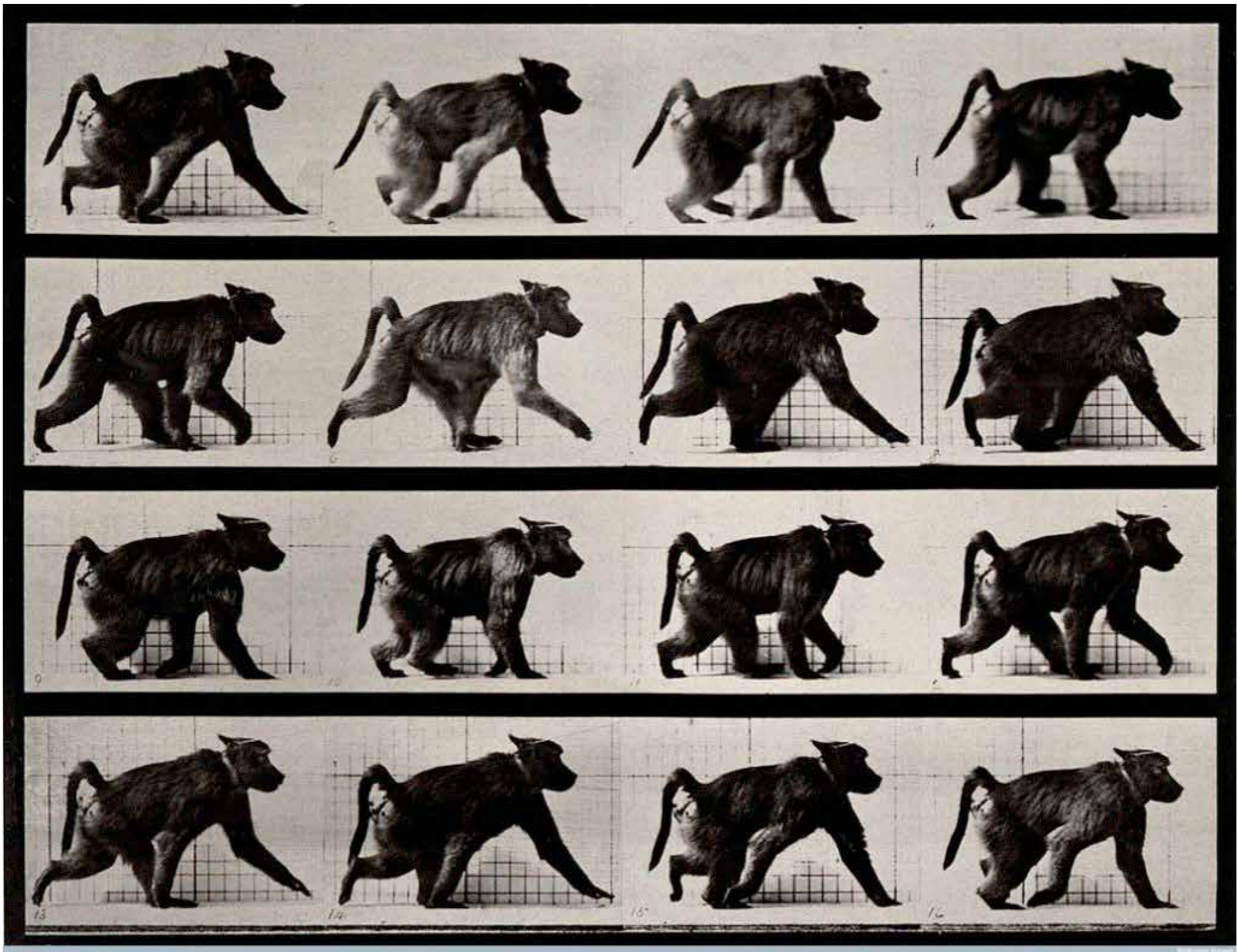

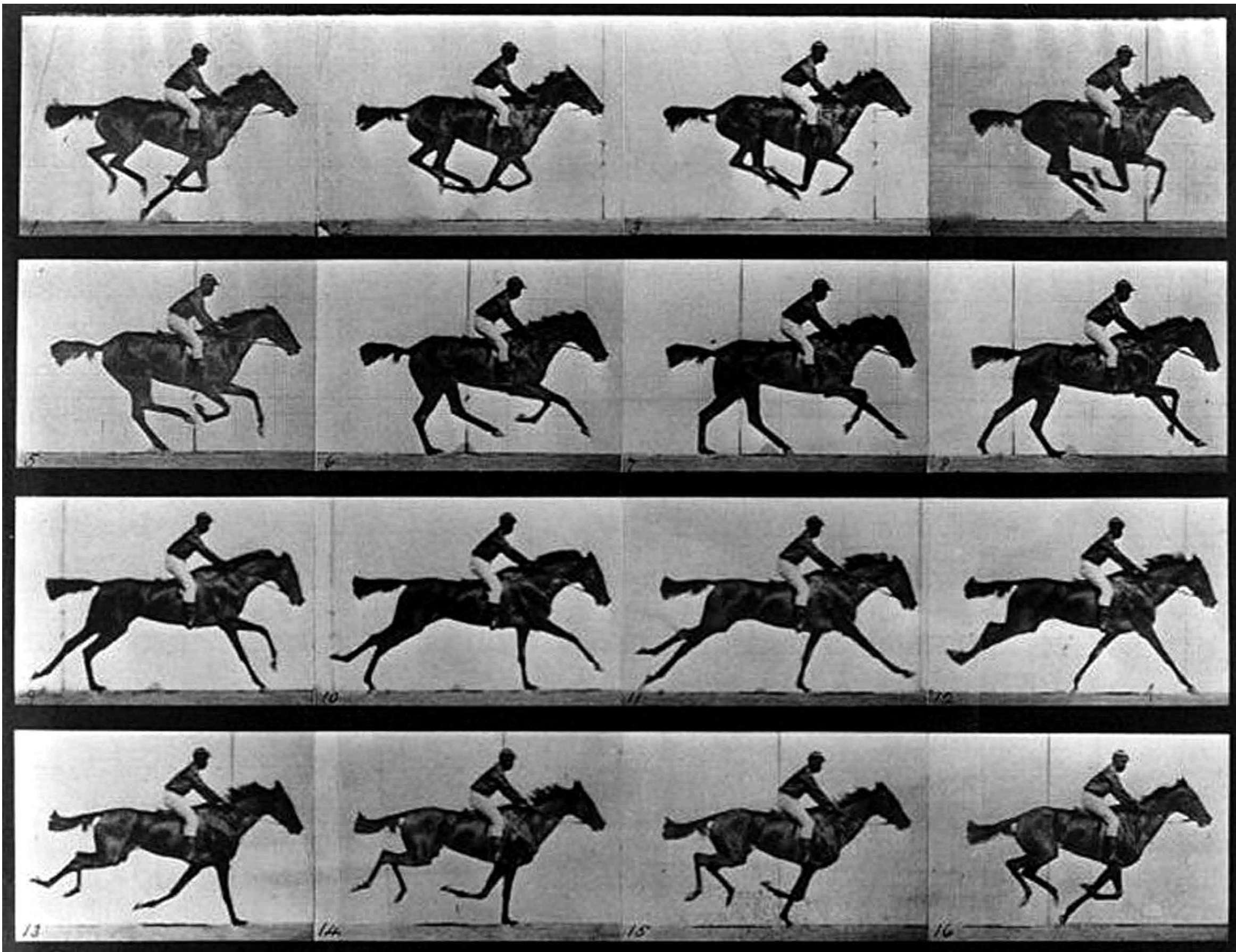

FRATELLI LUMIÉRE





FRATELLI LUMIÉRE

FRATELLI LUMIÈRE



PAUL STRAND



PAUL STRAND



PAUL STRAND

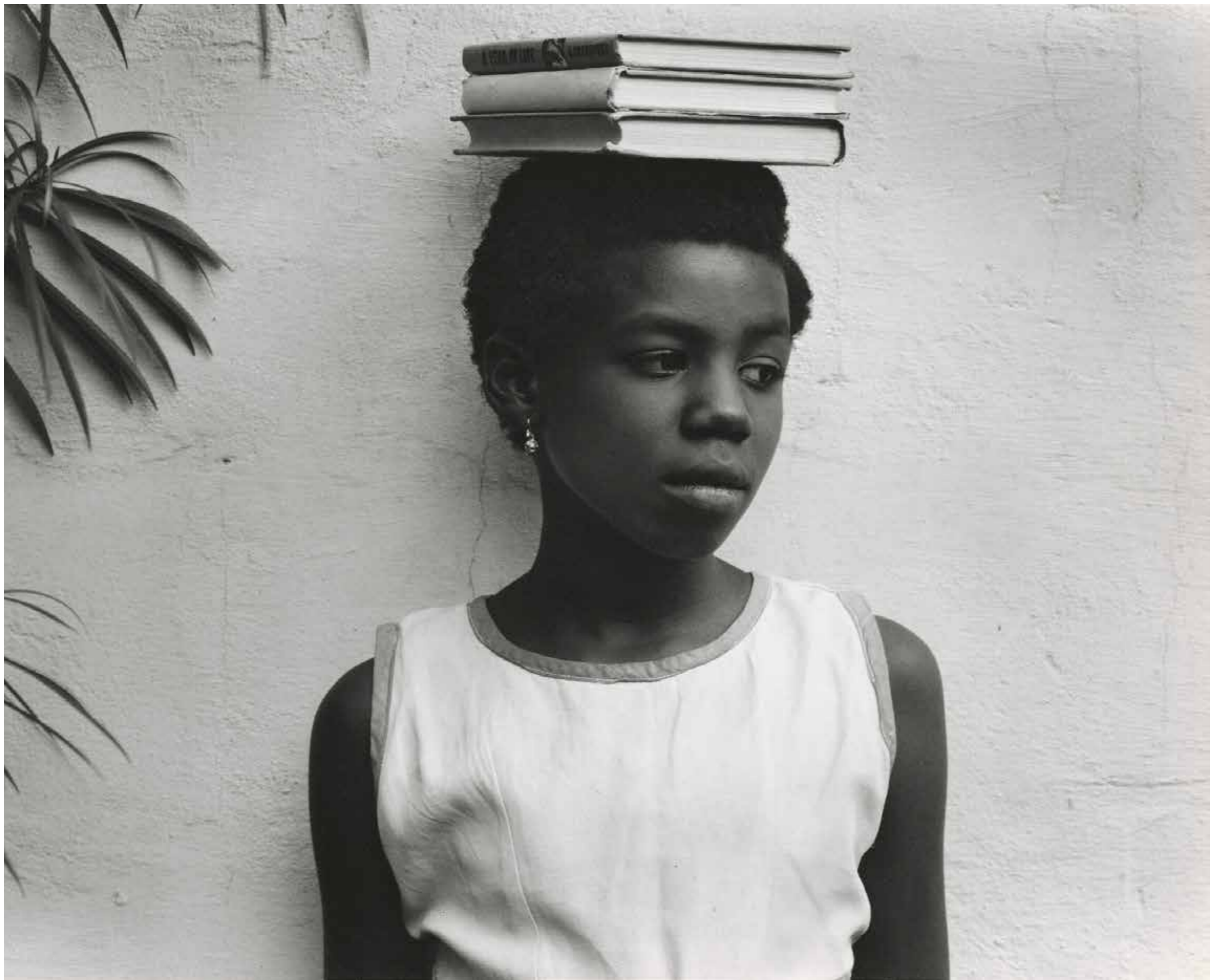



SALVADOR DALÌ

MAN RAY

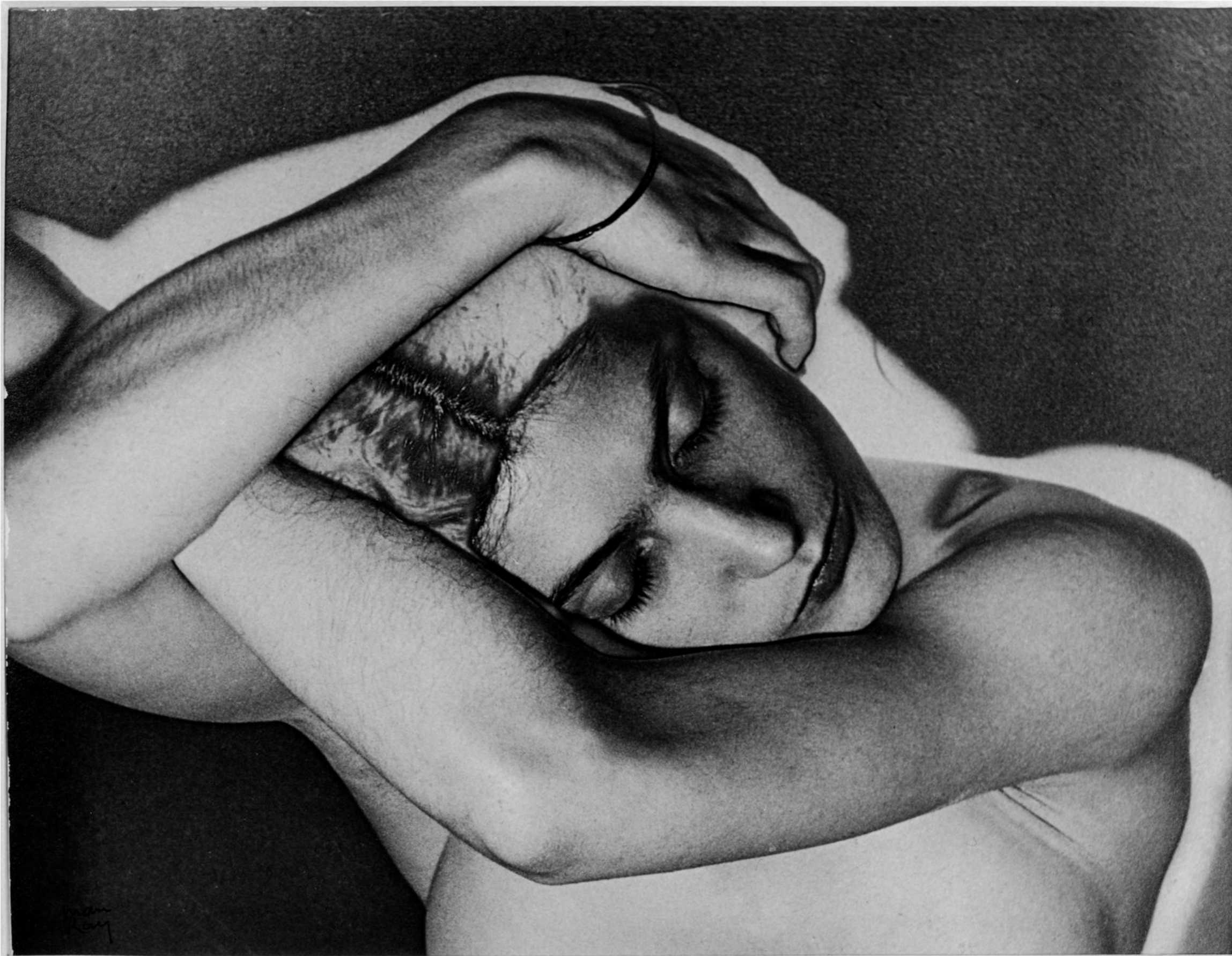

MAN RAY



1950 - ANSEL ADAMS

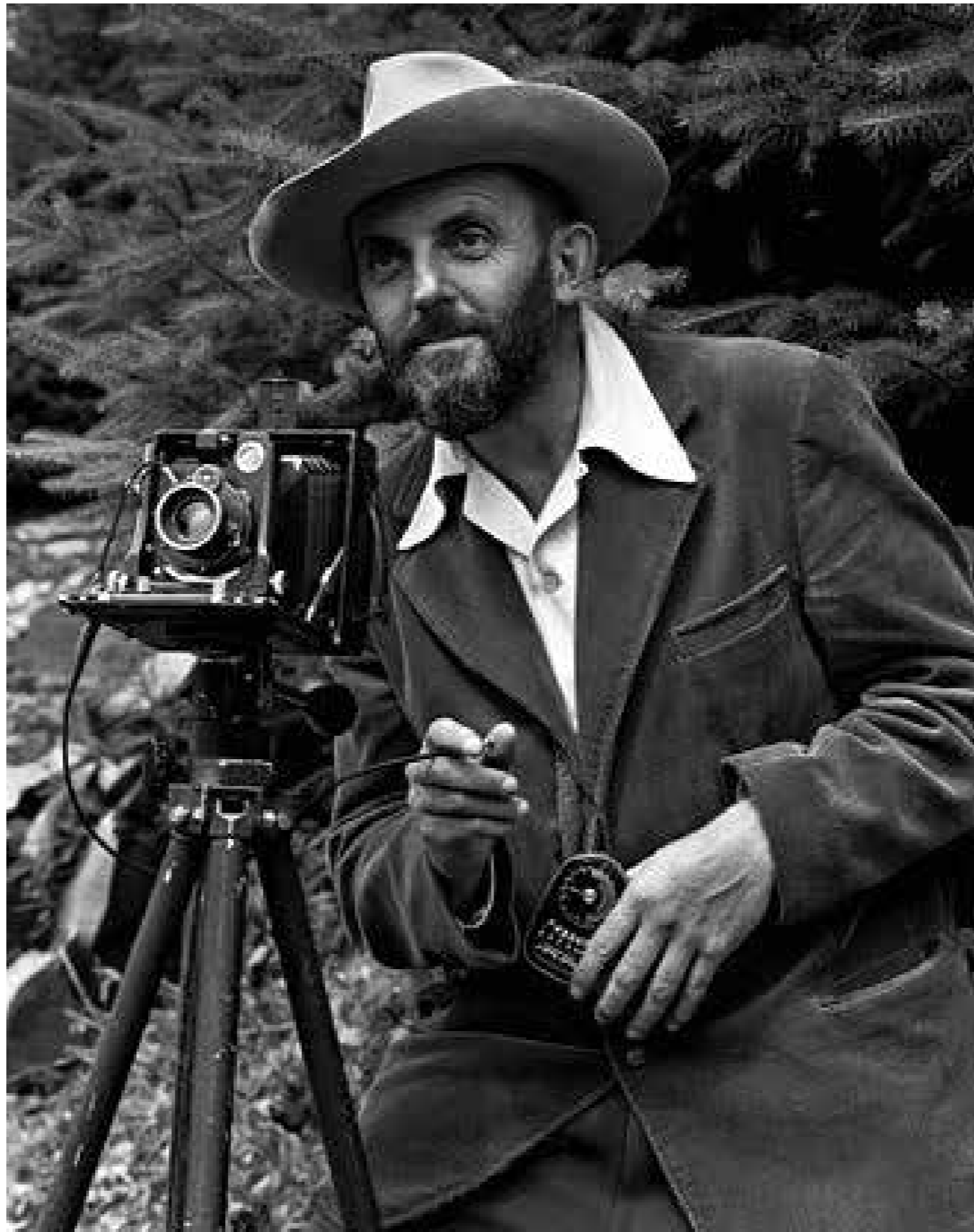

ANSEL ADAMS



ANSEL ADAMS



EDWARD WESTON



EDWARD WESTON



EDWARD WESTON





EDWARD WESTON

HENRI CARTIER BRESSON



HENRI CARTIER BRESSON



HENRI CARTIER BRESSON

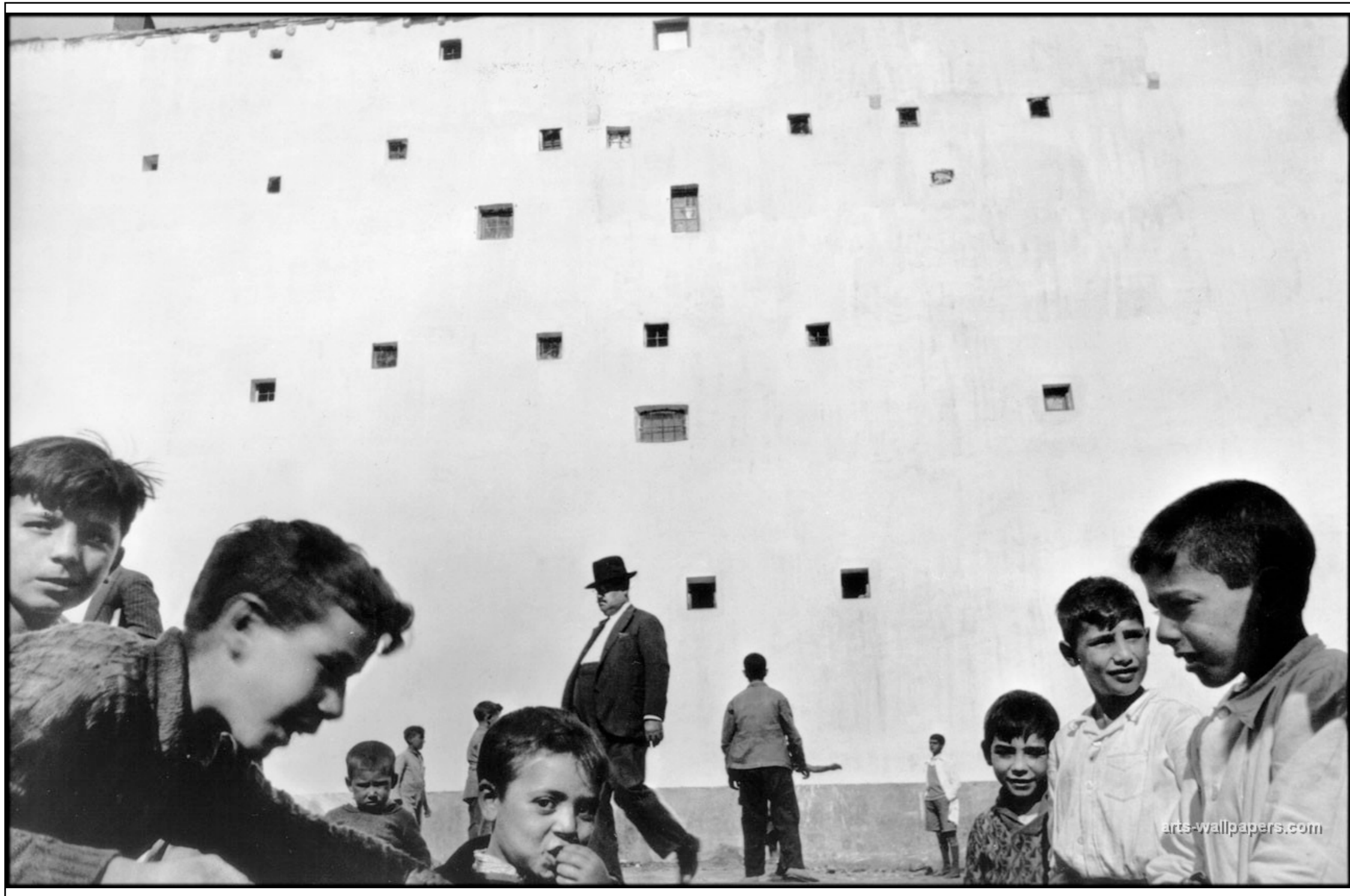

HENRI CARTIER BRESSON



HENRI CARTIER BRESSON



HENRI CARTIER BRESSON



HENRI CARTIER BRESSON



CECIL BEATON



WILLIAM KLEIN



WILLIAM KLEIN



CECIL BEATON



CECIL BEATON



VIVIAN MAIER



© Vivian Maier: Street Photographer edited by John Maloof, published by powerHouse Books

ROBERT FRANK



ROBERT FRANK



JOSEF SUDEK



JOSEF SUDEK



IRVING PENN



RUSSEL KIRSCH - 1958 prima fotografia digitale



PROTOTIPO KODAK DIGITALE



STEVEN SASSON



IRVING PENN



NIGEL RICHARDS

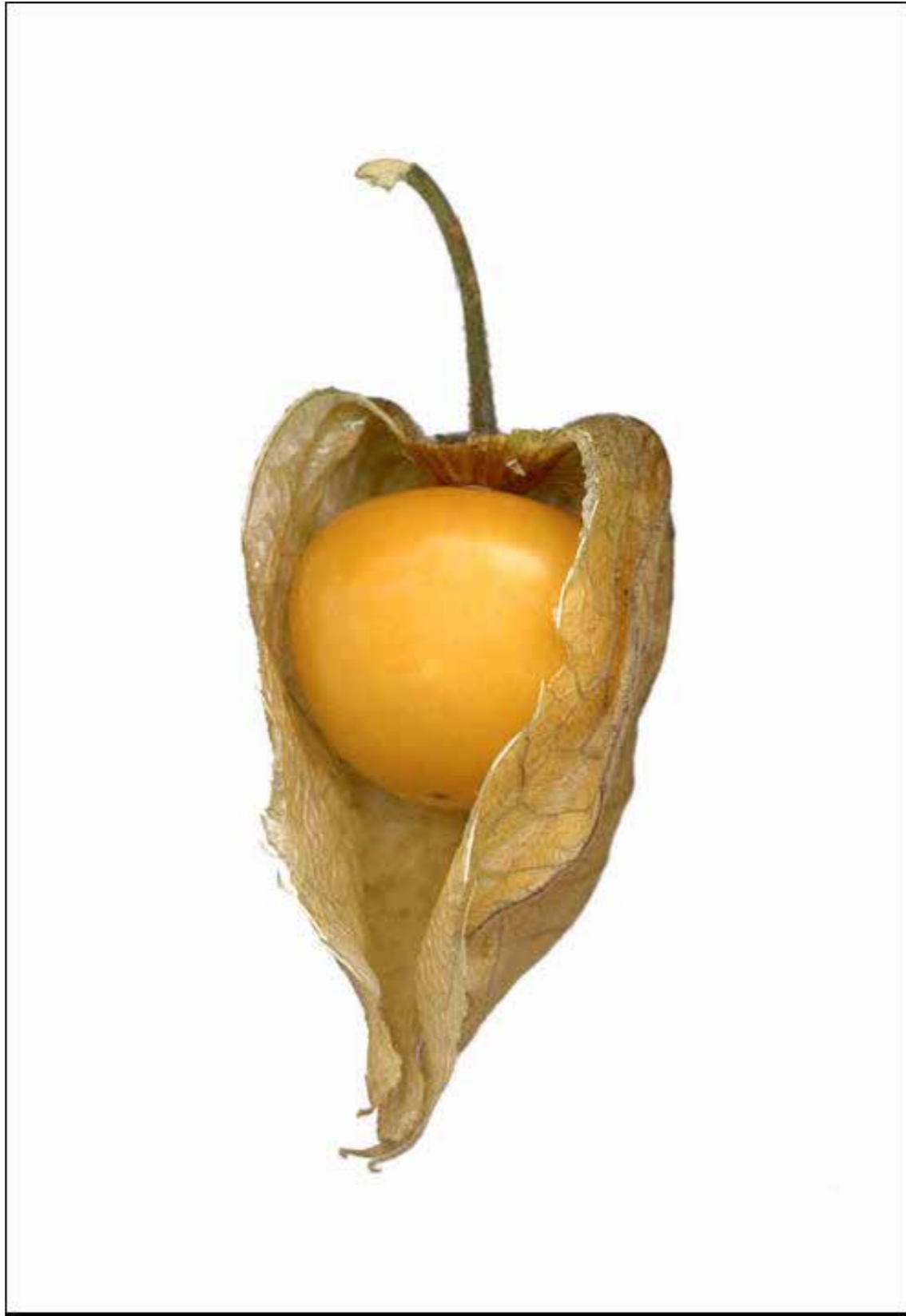



ALFRED EISENSTAEDT
GLENN EDWARD MC DUFFIE - EDITH SHAIN